

Harlequin 12-sided Panel Tanks: POP 120 – 300

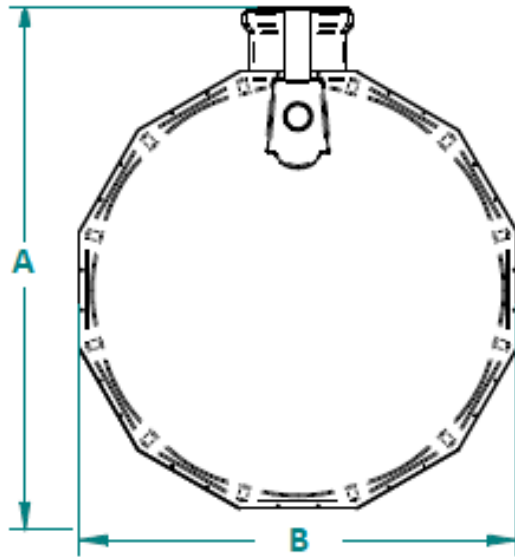

	A (mm)	B (mm)	C (mm)	D (mtrs)	E (mm)	No of Turrets	Power Requirements (KWhr/Day)	Unit Weight (kg)
HPDD-120	3270	2720	900	7.7	975	4	17.3	2180
HPDD-140	3270	2720	900	8.4	975	5	19.4	2510
HPDD-160	3270	2720	900	9.1	975	5	21.6	2710
HPDD-180	3270	2720	900	9.1	975	5	22.8	2810
HPDD-200	3270	2720	900	10.5	975	5	25.9	3100
HPDD-220	3270	2720	900	11.2	975	5	30.2	3300
HPDD-240	3270	2720	900	11.2	975	5	32.4	3390
HPDD-260	3270	2720	900	12.6	975	6	34.6	3810
HPDD-280	3270	2720	900	13.3	975	7	36.7	4130
HPDD-300	3270	2720	900	13.3	975	7	43.2	4220

*All values in table are subject to change

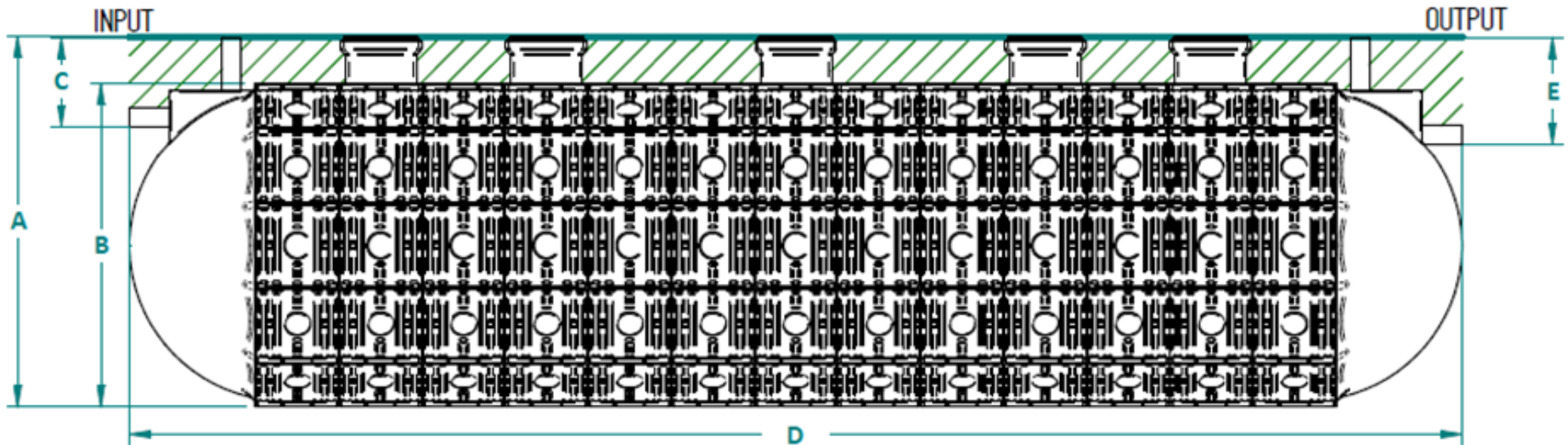

Notes:

1. This drawing is for 'dimensional information' only, it is essential that this drawing is read in conjunction with the installation guidelines supplied with the unit.
2. All pipe connections are $\varnothing 160\text{mm}$ PVCu.
3. Blower assemblies mounted externally, within 10m of treatment plant.